

# LIFE



## Neutronic studies on the impact of wall shielding penetrations for laser IFE systems

**Antonio Lafuente**  
**Kevin Kramer**  
**Jeff Latkowski**

# LIFE's availability will be enabled, laser-wise, by higher redundancies and the ability to perform maintenance during operation



**Redundancy can be achieved by arranging each laser into a beam group array**

- Beam groups consist of 2x4 arrays of beams

The failure of one beam within the array can be compensated by adjusting the power of the rest



**Maintenance during operation is assured by keeping the neutron dose low in the laser bay**

This can be enabled by a double neutron pinhole

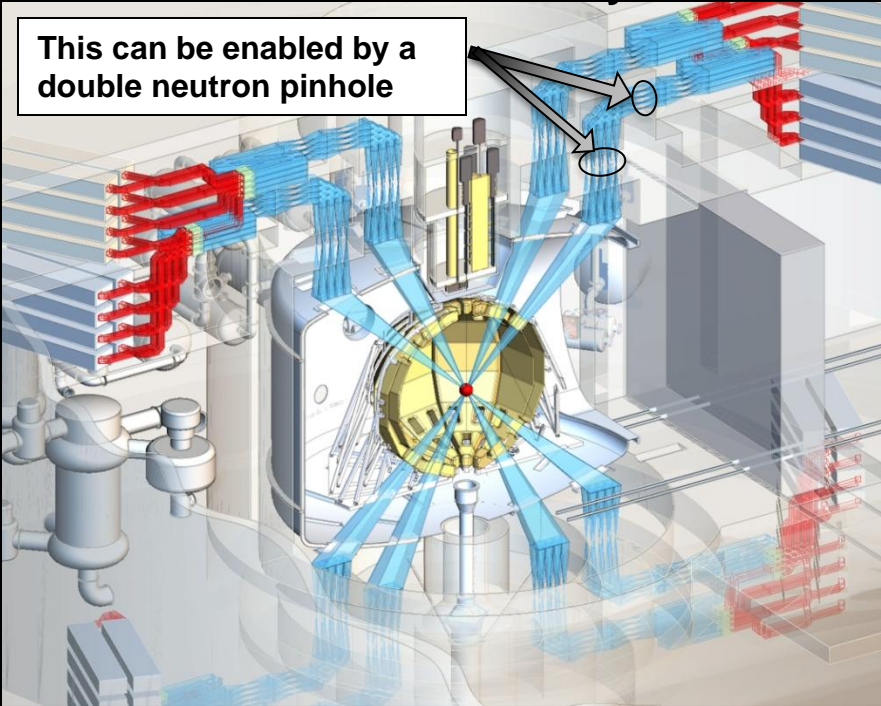

**Dose rate after two neutron pinholes will be <50 mrem/y**

# Since pinholes' presence drive dose effects after the wall it is important to have a better understanding on their influence

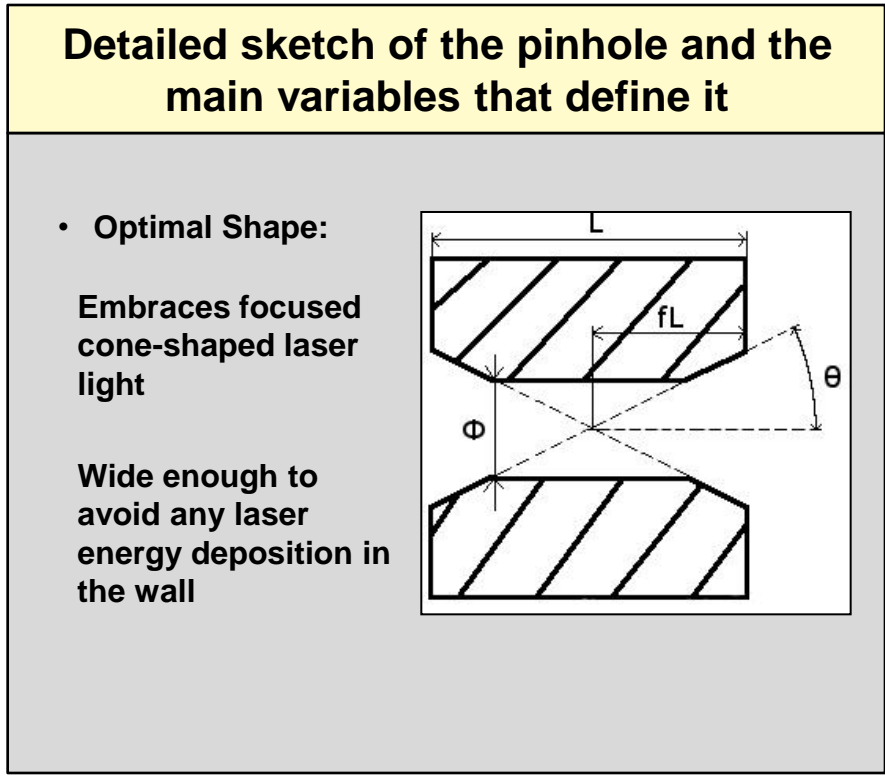
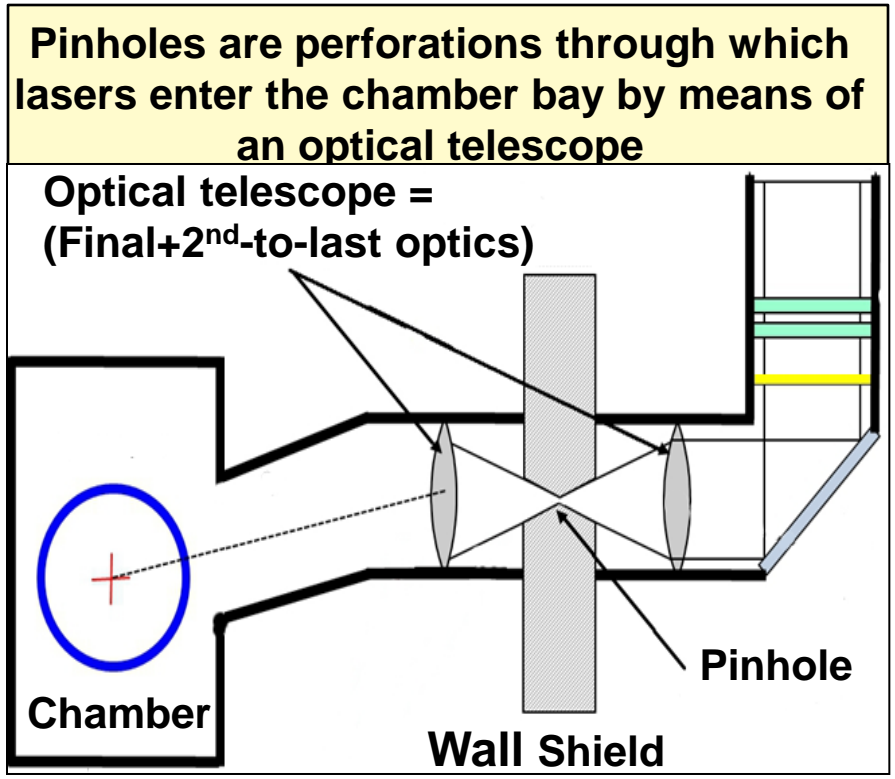

**By adjusting the pinhole's variables we can reduce the dose rates in the laser bay to acceptable levels**

# We have studied the impact of the pinhole variables on the laser bay by means of a 3-D neutronic model

---

- The model captures the details of a conceptual yet representative geometry
- MCNP radiation transport code has been used for this purpose
- ICRP-74 flux-to-dose conversion factors
- Dealing with a deep penetration problem required the use of variance reduction techniques
- Several parametric studies have been performed for a single wall shielding design

# Dose in laser bay is dominated by pinholes' existence and minimized for small neutron pinholes

Dose rate in chamber and laser bay as a function of distance to the chamber center for different pinhole diameters (Single pinhole)

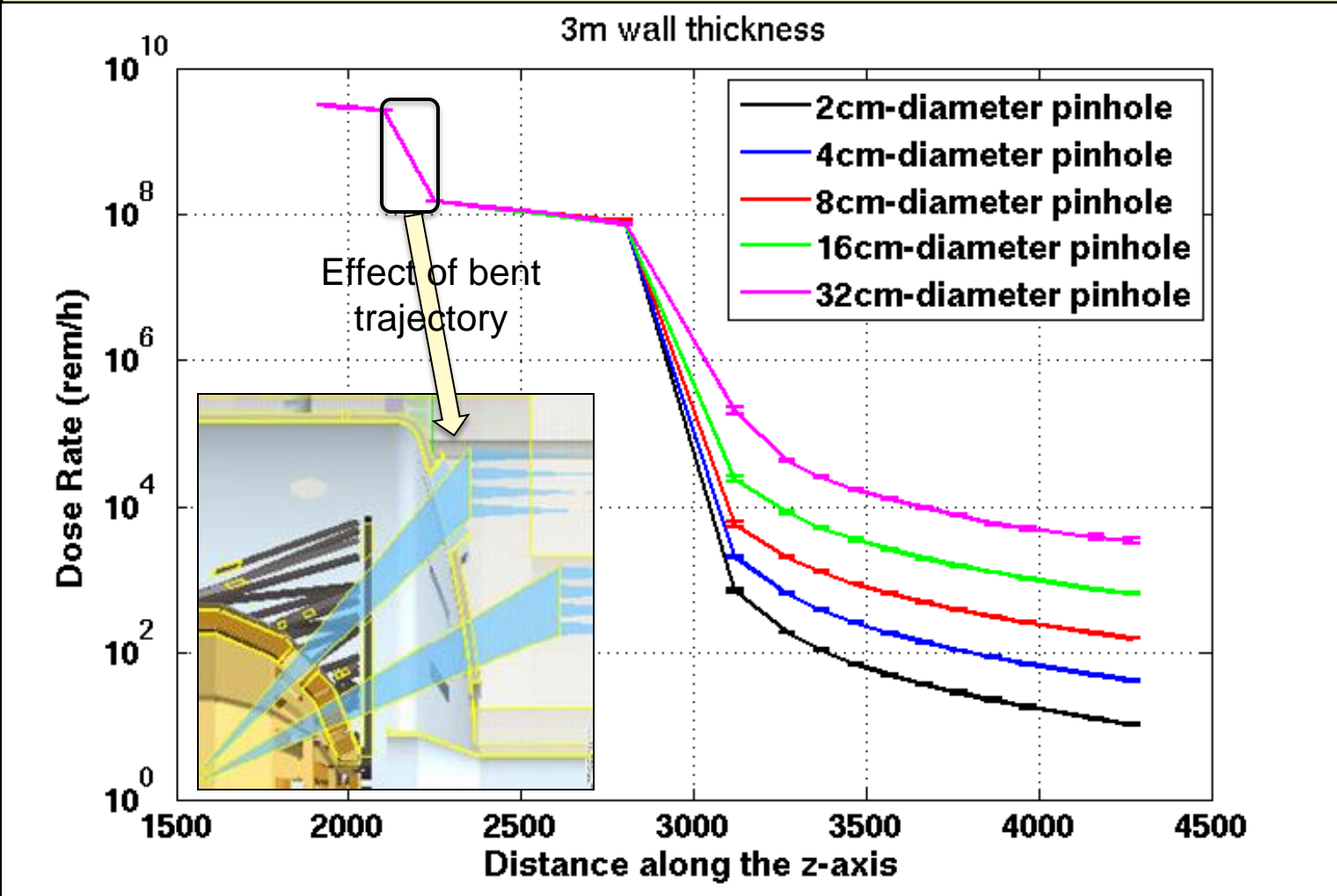

# The pinhole's size is traded off with laser requirements

Dose rate in second-to-last optic as a function of pinhole diameter for different wall thicknesses (Single pinhole)

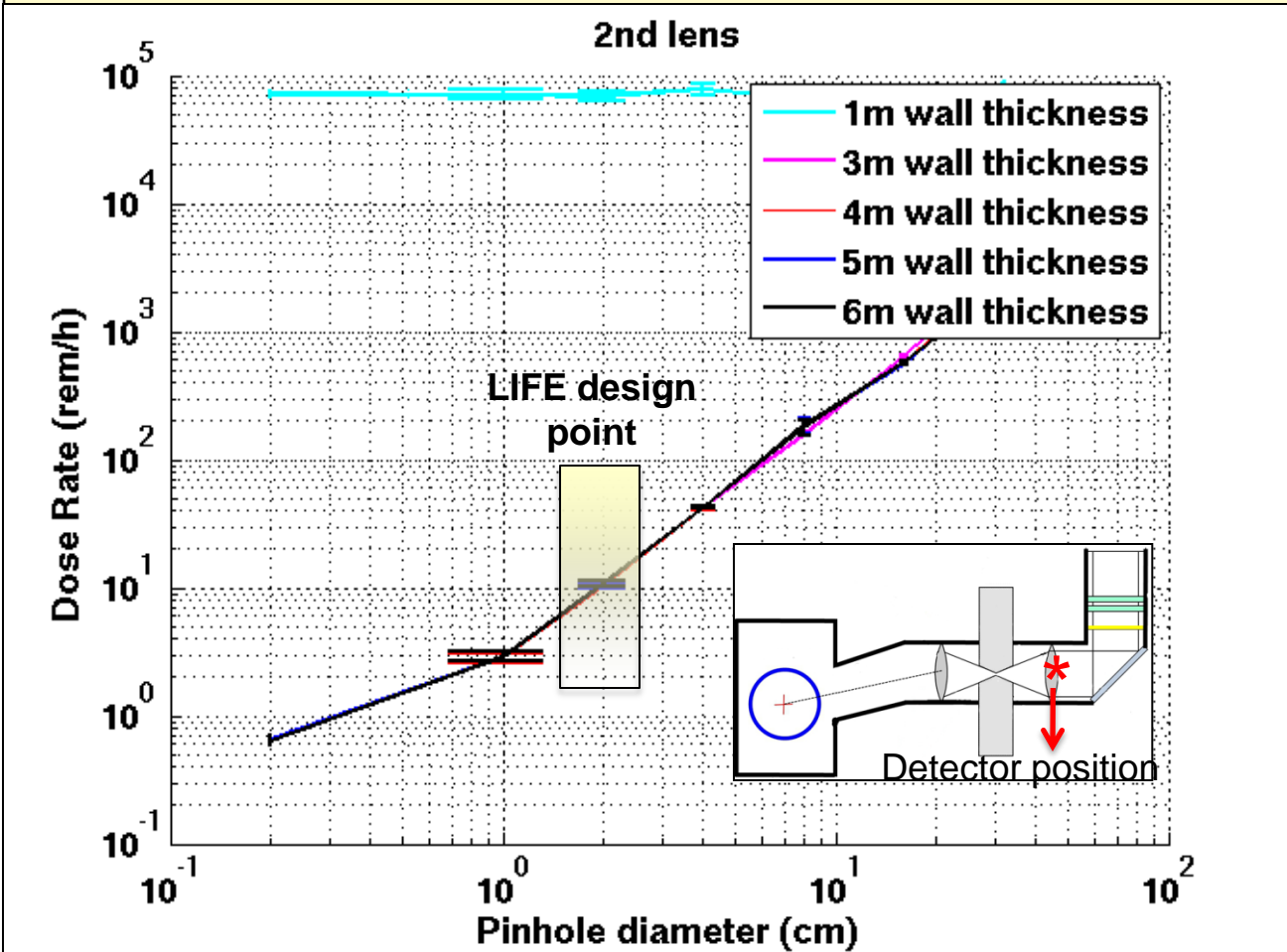

# Dose rates do not fall for shield walls thicker than ~3m

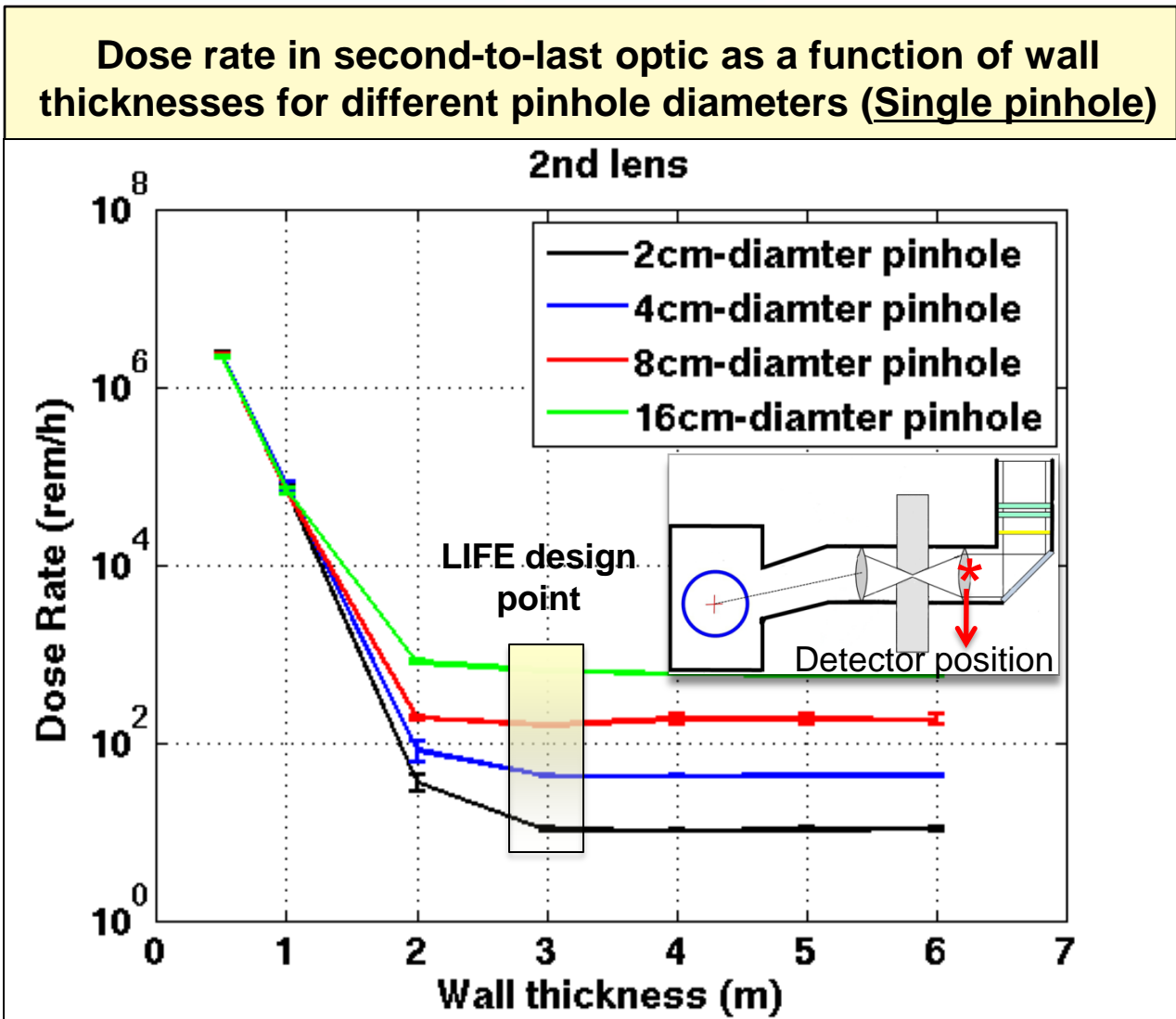

**Above ~3m  
pinhole effects  
dominate**

# Pinhole results favor low acceptance angle and central placement within the shield wall

Dose rate in second-to-last optic as a function of pinhole position for half-angles (Single pinhole)

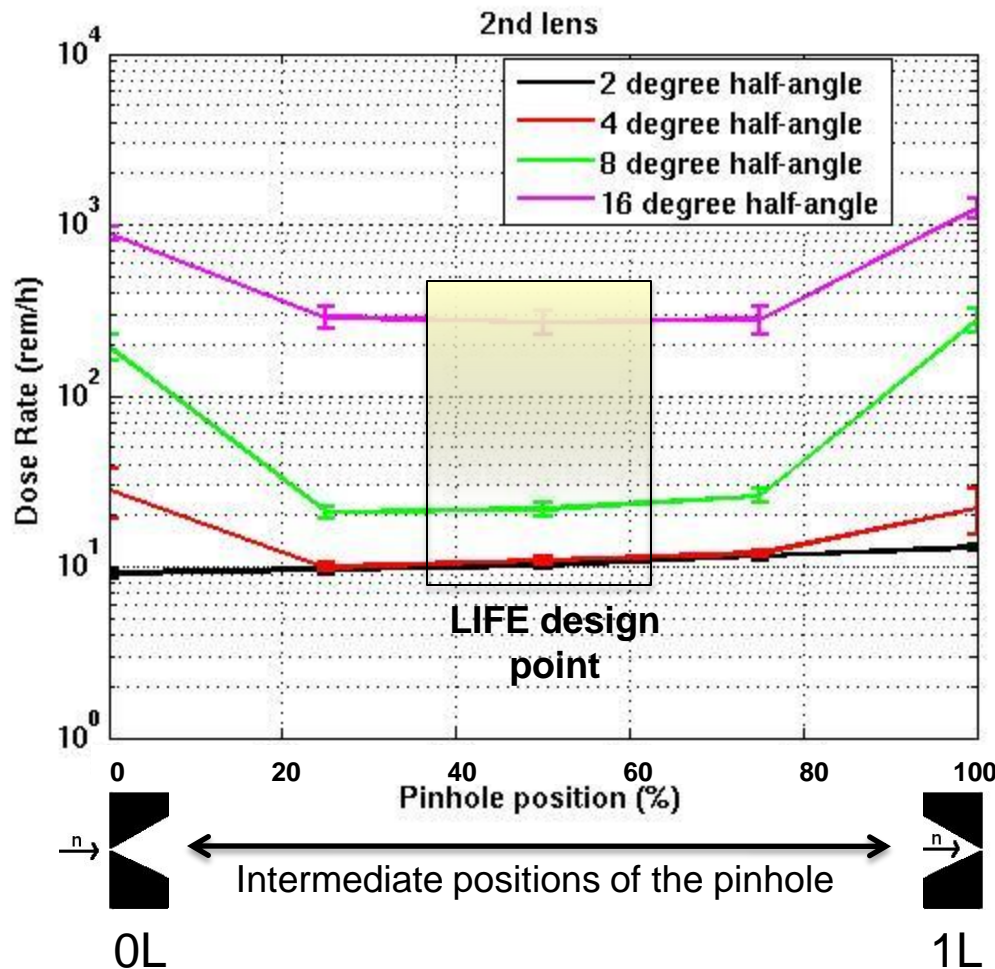

Simplified pinhole sketch

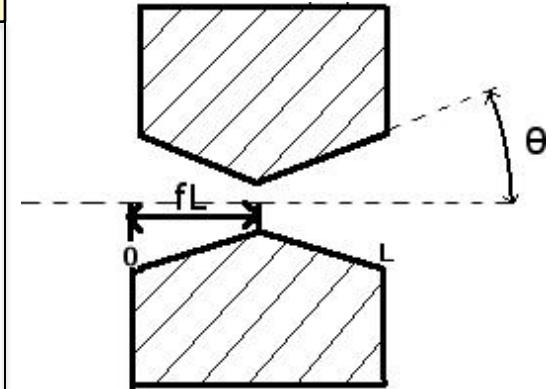

Two effects pull in different directions:

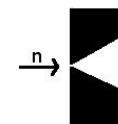

Pinholes cross talk

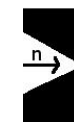

Funneling effect

# A second neutron pinhole is needed to meet the dose requirements

- Single wall concept does not fulfill our criteria
- Design criteria for worker access limits doses to 500 mrem/y

**ALARA goal is 10x lower**

- Urged by the results, and having identified some trends, a second wall with an additional set of pinholes was analyzed

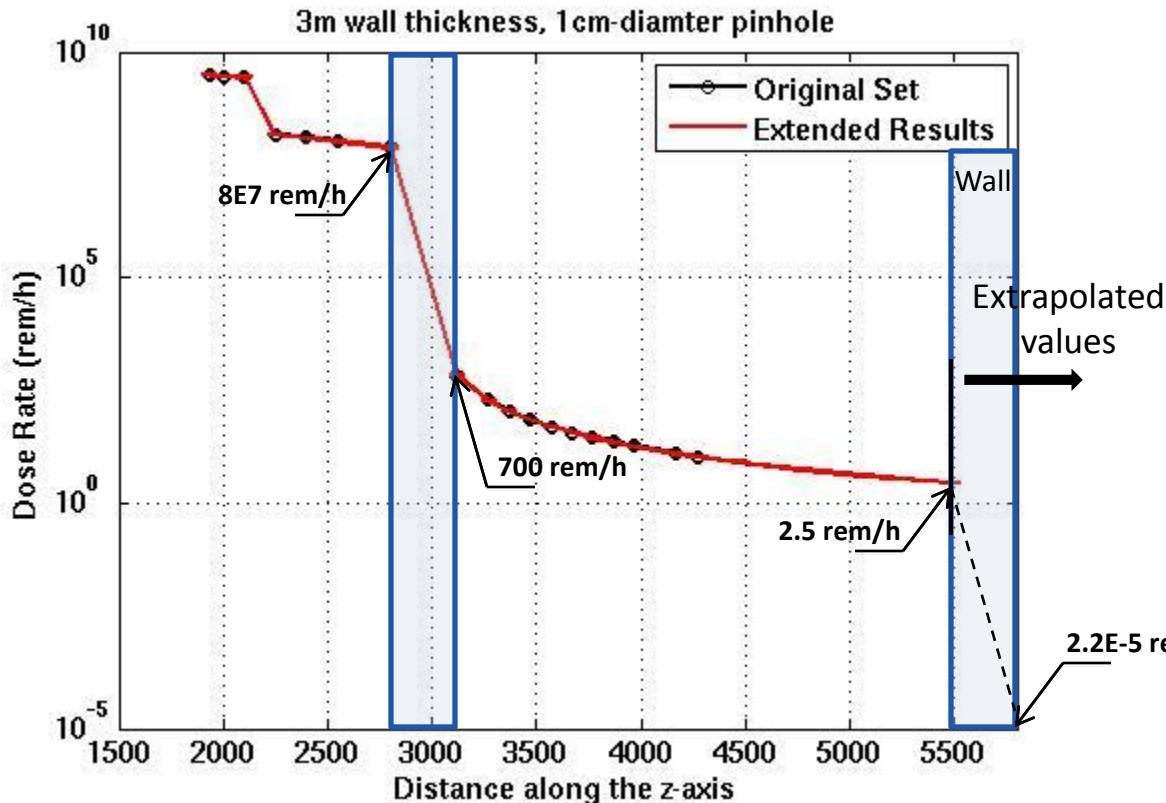

**Simple calculations pointed in the right direction**

2.2E-5 rem/h → 44 mrem/y for worker (2000 hrs)

# We have conceptualized a design that minimizes the size imposed by a second wall by bending the laser path

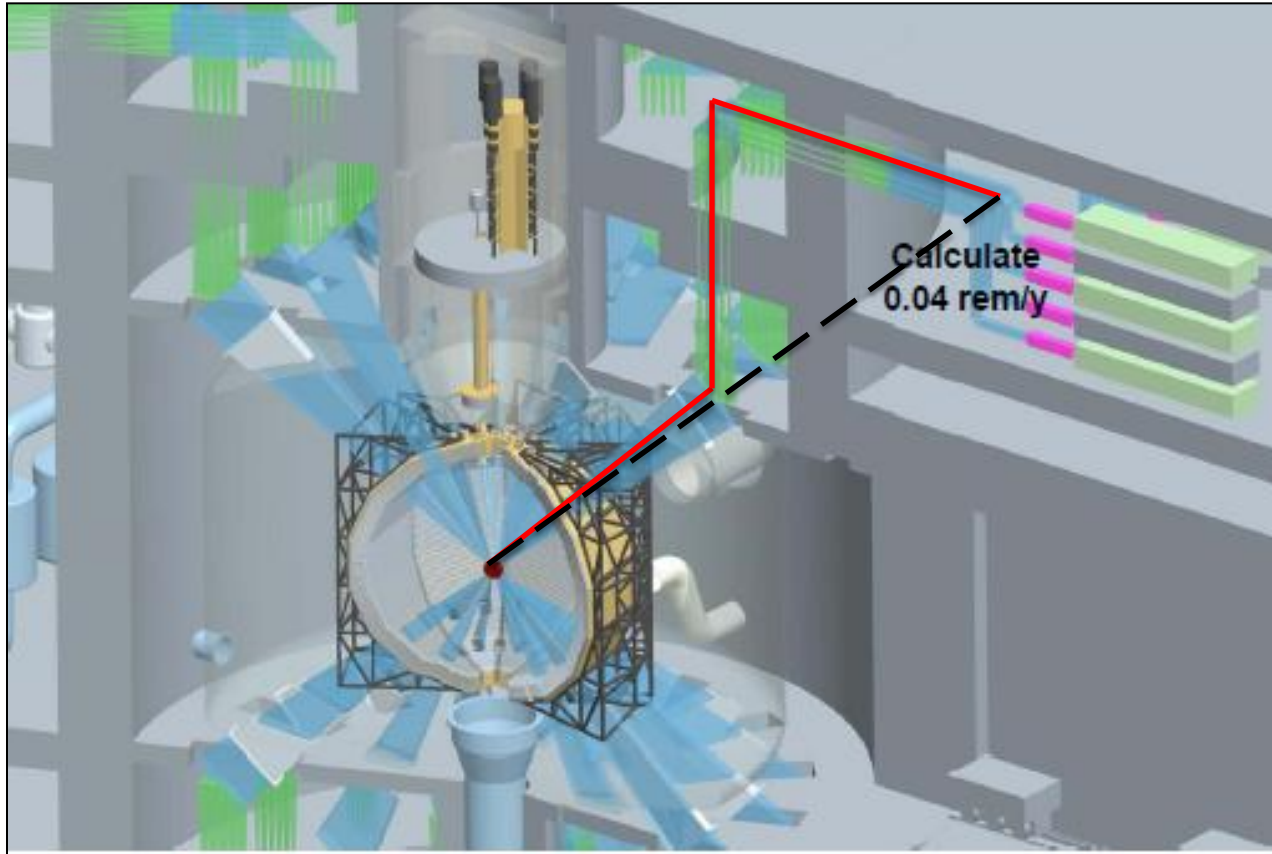

There are two different paths a particle can take to get to the laser bay:

— Through beam tubes

— Through walls

# From a conservative approach, both paths result in satisfactory dose reductions

**Estimated dose reduction through the beam tubes  $> 10^{15}$**

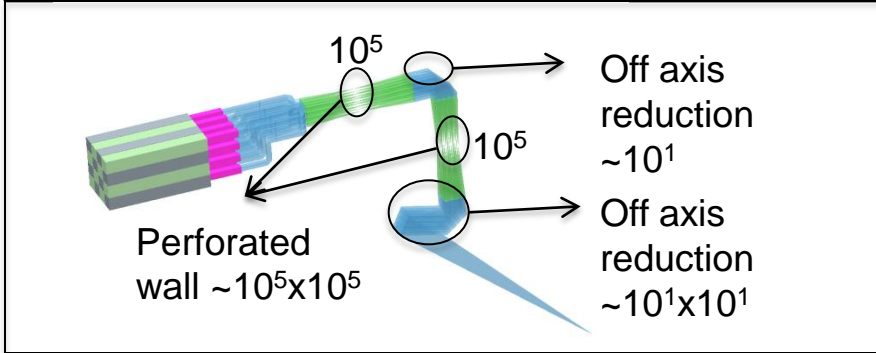

**Estimated dose reduction through the walls  $> 10^{15}$**

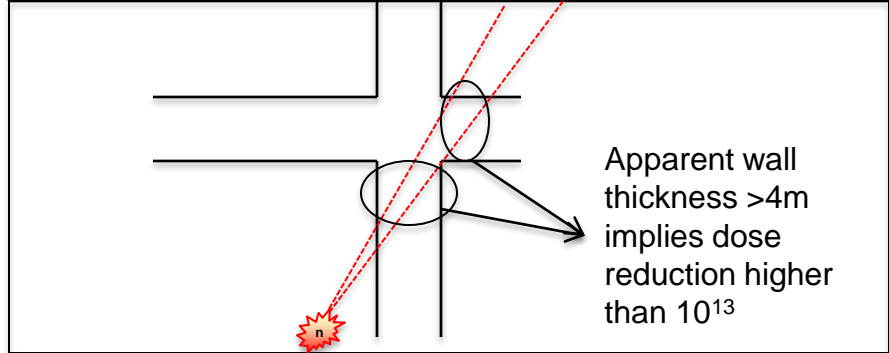

**Results validated on a simplified model**

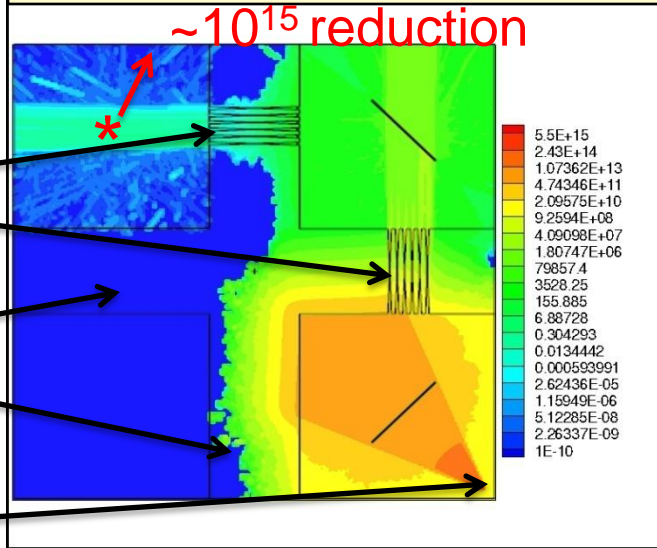

Pinholes

Wall shielding

Neutron source

**The same dose reductions over the different geometric features were successfully predicted**

# Low dose rates (<50mrem/y) after a double neutron pinhole will guarantee maintenance during operation

---



- We can conservatively say that the new “double pinhole” concept fulfils the maintenance requirement during operation
- This will enable highly available systems
- We now have a better understanding of the influence of wall shielding penetrations in IFE that could serve as guidelines for future designs
- Future work over the final point design could include the use of CAD-to-MCNP converters, Deterministically-generated adjoint (importance) functions for Monte Carlo variance reduction or the use of 3D deterministic codes

LIFE

